

HIGH-PRECISION MEASUREMENT AND CALIBRATION TECHNOLOGY AS A BASIS FOR CORRECT GAS BILLING

23rd World Gas Conference, Amsterdam, 2006

M. Uhrig, P. Schley, M. Jaeschke, D. Vieth, K. Altfeld, I. Krajcin

E.ON Ruhrgas AG
45326 Essen, Germany

Abstract

The gas measurement stations of the gas transmission grid normally handle hourly rates of several 100,000 m³. The import stations often even manage several million cubic metres per hour. The resulting high product value requires that the energy quantities received or delivered be measured with maximum precision. This is even more important considering the liberalisation of the gas market and increased trading of different natural gases. Complex measurement technology is the basis for correct billing of the energy quantities delivered to customers. To ensure compliance with these high requirements for measurement accuracy, E.ON Ruhrgas has test and calibration facilities available, such as the pigsar™ high-pressure gas meter test facility, the Lintorf high-pressure test rig and the company's Gas Quality Centre. The paper describes these test and calibration facilities and presents the latest developments and results.

pigsar™ is one of the world's leading calibration facilities for high-pressure gas meters. It serves to calibrate gas meters for customers throughout the world, ensuring maximum quality and flexibility. pigsar™ is accredited in accordance with EN ISO/IEC 17025. In 1999, Physikalisch Technische Bundesanstalt (PTB), the German national metrology institute, officially declared pigsar™ the national primary standard for one high-pressure cubic metre of natural gas. This standard has then been harmonised with the corresponding reference standard of the Netherlands (NMI) and, since 2004, also with the reference standard of France (LNE). Recent round robin tests (key comparisons) supervised by the Comité International des Poids et Mesure (CIPM) confirmed this European high-pressure natural gas cubic metre to be identical with the key comparison reference value (world reference value) (see [1]). Gas meters are now calibrated on pigsar™ which uses this world reference value involving the lowest uncertainty achievable so far (0.16 %, double standard deviation). In order to further improve metrological performance, flexibility and safety, several new installations were commissioned over the past two years, some of which will be described in this paper. The metrological and economic meaning of the CIPM key comparison reference value and its relationship with the harmonised European gas cubic metre will be addressed by Dopheide et al. in a separate paper at the 2006 WGC (see [2]).

It is necessary to guarantee the accuracy of gas meters not only during calibration or verification but also during their permanent use in the field. This requires thorough knowledge of meter behaviour under different typical operating conditions. On the Lintorf high-pressure test rig, gas meters are tested for use in bulk gas metering under ideal and disturbed flow conditions. For this purpose, experts of E.ON Ruhrgas examine, under near-field conditions, all factors influencing meter behaviour during operation as well as their effects on meter readout. Relevant factors are, for example, flow perturbations such as swirl, disturbed velocity profiles, and pressure and speed pulsations. The measured data serve to

- quantify various factors influencing meter readout,
- optimise measurement instruments, and
- solve operational problems.

Aside from flow rates, gas property data, such as superior calorific value or normal density, are also required to accurately determine energy quantities delivered and thus ensure correct billing. High precision measurement of these data is therefore also of great importance. The Gas Quality Centre of E.ON Ruhrgas makes a major contribution to ensuring precise gas quality measurement in Germany. As a state-approved test centre, the E.ON Ruhrgas Gas Quality Centre certifies approx. 400 calibration gases annually. They serve as working standards for the calibration and verification of gas quality measurement instruments. An application for having the Gas Quality Centre accredited as a test and calibration laboratory pursuant to ISO 17025 has recently been filed. Once accredited, the certificates issued by the Gas Quality Centre will be accepted on an international level. The spectrum of reference measurement instruments is probably unique in Europe. For example, the Gas Quality Centre has a number of laboratory measurement systems available for the highly accurate determination of density and other physical data (e.g. speed of sound, dielectric permittivity). With density measurement instruments developed by Ruhr University of Bochum, Germany, the Gas Quality Centre achieves an accuracy of 0.02 %. A reference calorimeter was set up and developed under a GERG project which aims to determine the superior calorific value with an uncertainty of less than 0.05 %.

Inhalt

Abstract	2
1.0 INTRODUCTION	5
2.0 pignar™	5
3.0 LINTORF TEST FACILITY	10
4.0 GAS QUALITY CENTRE	12
4.1 Precision Densimeter	13
4.2 Reference Calorimeter	16
5.0 OUTLOOK	17
6.0 REFERENCES	18
7.0 LIST OF TABLES	19
8.0 LIST OF FIGURES	19

1.0 INTRODUCTION

In fiscal gas metering, the quantity of energy delivered must be known very accurately, in particular in natural gas transportation over long distances. The annual natural gas consumption in Germany amounts to approx. 97 billion m³ and is covered by gas from several reliable sources of supply in and outside of Germany. The share of natural gas imported from abroad amounts to more than 80 %. The gas measurement stations of the gas transmission grid normally handle hourly rates of several 100,000 m³. The import stations often even manage several million cubic metres per hour. The resulting high product value requires that the energy quantities received or delivered be measured with maximum precision. This is even more important considering the liberalisation of the gas market and increased trading of different natural gases. Complex measurement technology is the basis for correct billing of the energy quantities delivered to customers. The measurement of volumes at operating conditions and determination of gas properties are of great importance to the acquisition of accurate energy quantities. For this purpose, E.ON Ruhrgas has test and calibration facilities available to ensure that high measurement requirements are met, such as the pigsar™ high-precision test facility, the Lintorf high-pressure test rig and the Gas Quality Centre. This paper presents the latest developments and results for these test and calibration facilities.

While both the Lintorf [3] and pigsar™ [4] test rigs are two highly accurate high-pressure facilities of E.ON Ruhrgas for testing volume meters, their intended purposes are basically different. pigsar™ is a state-approved calibration laboratory and German standard for high-pressure gas measurement. It was designed for the certification of gas meters and is therefore an independent laboratory. The high pressure test rig in Lintorf is primarily intended for use in R&D projects. It is also made available for external services.

The Gas Quality Centre performs a number of activities or offers services which serve to determine the property data relevant to gas billing as accurately as possible. For example, it certifies, among other things, calibration gases for process gas chromatographs (PGCs) and verifies gas property measurement instruments. The Gas Quality Centre has a broad range of highly accurate laboratory apparatuses available which are used as reference standards.

2.0 pigsar™

E.ON Ruhrgas has been operating the pigsar™ high-precision test rig at its Dorsten facility jointly with PTB1 since 1993. Table 1 summarises its technical data and capabilities (see also [5]). In cooperation with and under the supervision of PTB, pigsar™ is responsible for maintaining and spreading the German reference unit of volume for natural gas under high-pressure conditions. Thanks to its excellent metrological performance, high flexibility and availability over the year, pigsar™ is widely accepted as one of the world's leading calibration facilities. This is confirmed by more than 800 calibrations annually mostly performed for international customers. The types of meters calibrated mainly include turbine meters, ultrasonic meters, vortex meters, Coriolis meters and, in some cases, rotary piston meters and pressure differential devices like orifices and venturi meters.

On 12 May 1999, PTB approved pignar™ as the German reference standard for one high-pressure cubic metre of natural gas. Under the Dordrecht Contract, the national measurement chains for high-pressure natural gas of Germany and the Netherlands (NMI2) were harmonised on 2 June 1999. In 2004, the French metrology institute (LNE3) joined the harmonisation project and the European high-pressure natural gas cubic metre was created. It has since been represented by pignar™ together with the corresponding laboratories in France (Alfortville) and the Netherlands (Bergum, Westerbork). The procedures and results of the harmonisation project are described in detail in [6].

¹PTB is the national metrology institute and national institute for science and technology as well as the highest technical authority in the field of metrology in the Federal Republic of Germany. ²National Meetinstitute Van-Swinden-Laboratory responsible for maintaining and spreading standards in the Netherlands. ³Laboratoire National de Métrologie et d'Essais responsible for metrology in France.

Table 1: Technical data of pignar™

Flow range	8 m ³ /hr to 6,500 m ³ /hr at operating conditions up to 350,000 m ³ /hr at reference conditions
Pressure range	16 bar to 50 bar
Temperature range	8 °C to 20 °C (stability during test < 0.1 K)
Sizes of meters under test	up to DN 400
Length of meter run	Standard: up to 15,5 m (longer installations possible upon request)
Working standards	8 parallel runs with turbine meters 1 parallel run with rotary piston prover IRPP
Measurement uncertainty	max. 0.16 % (double standard deviation)
Number of meter runs	5

In a preparatory step, the World Trade Organisation (WTO) had requested the Comité International des Poids et Mesure (CIPM) to provide for uniform standards and certificates. In 2000, the Consultative Committee for Mass and Related Quantities (CCM) then commissioned the relevant German and Dutch institutes through the international Working Group for Fluid Flow (WGFF) to define standards and procedures for key comparisons between high-pressure test facilities on a worldwide level and make parallel comparisons. As a result obtained from these comparisons, CIPM/CCM confirmed the European high-pressure natural gas cubic metre as the world reference value for high-pressure natural gas in 2005 [2].

Figure 1 shows the facility's pipe layout and installations. Figure 2 gives an impression of the size of the installations. As can be seen from Figure 1, the gas flow is first filtered at the station inlet and then stabilised by a temperature and pressure regulator unit. The gas first passes the bench of working standards and then enters either one of the three meter runs or the new metering building described in more detail below. Even contaminated meters can be tested as meters to be tested are installed downstream of the working standards.

The maximum standard length of a meter run is 15.5 m. This length corresponds to 40 diameters of DN 400, 54 diameters of DN 300 or larger relative lengths for lower diameters. It is therefore easily possible to provide appropriate inlet lengths for in-series testing of two DN 400 meters. Even longer lengths can be realised upon request. In 2005, for example, a complete mobile metering station mounted on a truck was connected to pigsar™ and calibrated for customers from China.

The pigsar™ facilities were considerably expanded in 2003. Several new installations have been commissioned since in a new metering building. The facilities added include a new working section suitable for meter calibrations, the piston prover with transfer meters, a bench with eight critical nozzles and a meter run for the development of a new primary standard based on a sub-critical nozzle and the laser-Doppler technique, the so-called optical primary standard. Except for the new working section, most installations in the new metering building are owned by PTB. While E.ON Ruhrgas is operating the systems, PTB is mainly responsible for the field of metrology. Further improvements were made, for example, the low-flow working standard was replaced by a rotary piston prover (IRPP) developed by Elster-Instromet B.V. This measure improves repeatability for low flow rates. Also, small-diameter connections between the working standards and the meter to be tested were installed to reduce line pack effects.

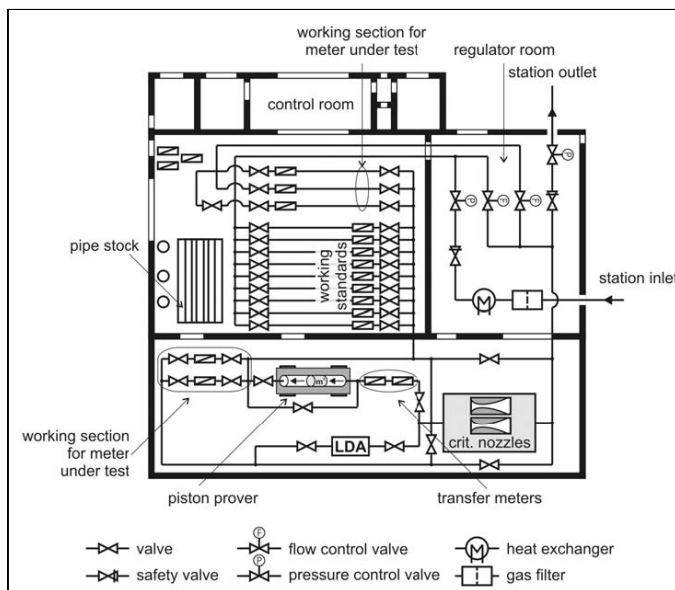

Figure 1: Schematic presentation of pigsar™



Figure 2: pigsar™: Working standards and meter test sections

The new working section consists of two new DN 200 meter runs. The runs were commissioned in early 2004 for the calibration of meters of up to DN 200. Now, a total of five meter runs are available, allowing much greater flexibility. The heart of pigsar™, the primary standard, is a piston prover with 250 mm inner diameter and a maximum flow rate of 480 m³/hr. The pigsar™ piston prover and traceability chain are explained in detail in several publications, (for example, see [7]). Thanks to the very short traceability chain, pigsar™ has the lowest uncertainty of all high-pressure gas calibration facilities. Until 2003, the piston prover had to be installed in one of the meter runs for each recalibration of the facility. Now, the prover is permanently integrated in the facility, thus significantly reducing recalibration times and improving reproducibility.

Over the past few years, PTB has been developing and testing a new optical primary standard. To measure high-pressure gas flow directly and in a single calibration step with different flow meters, the laser-Doppler technique was applied and a second independent primary standard was set up for pigsar™, the new optical flow rate standard. The basic idea of the concept is to measure volume flow Q_{op} by integrating flow velocity u across a well defined nozzle outlet section F :

$$Q_{op} = \int_F u dF$$

The flow rate measurement based on the measurement of velocity profiles at the nozzle exit plane is directly traced back to the SI units of length and time. Velocity is measured by a properly calibrated laser-Doppler Anemometer (LDA) using the optical access to the nozzle outlet in the high-pressure assembly. Additional measurements of temperature and pressure make it possible to determine mass and volume flow rates at reference conditions.

The shape of the nozzle was optimised using numerical methods including boundary layer calculations

to avoid flow separation in the nozzle and obtain a homogeneous velocity profile in the outlet. Flow acceleration in the nozzle considerably reduces turbulence. Profiles can thus be measured in a very repeatable and fast manner.

Three nozzles were designed to cover the flow rate range of all transfer standards used by pigsar™ (8 m³/hr to 1,600 m³/hr) in such a way that the velocity at the nozzle outlet does not exceed approx. 50 m/sec. This ensures optimal conditions for LDA signal processing. The nozzles were designed as three compatible inserts of the LDA nozzle module. The module is fitted with two high-pressure glass windows to provide the optical access required for LDA velocity measurements at the nozzle outlet surface (see Figure 3).

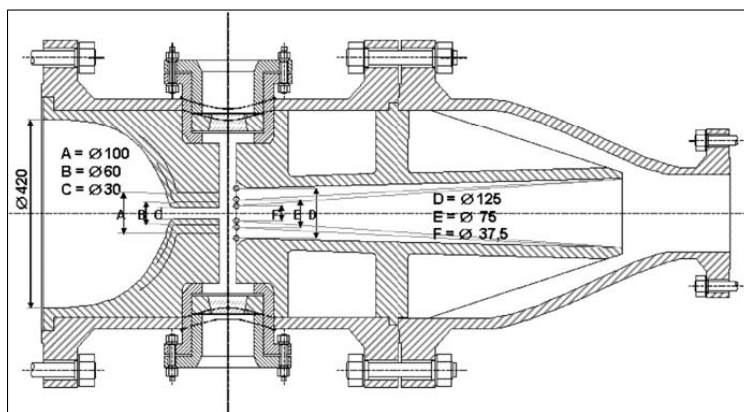

Figure 3: LDA nozzle module of the new optical primary standard with three exchangeable LDA nozzles

A: 120 to 1,600 m³/hr (k = 18); B: 25 to 500 m³/hr (k = 49); C: 6 to 120 m³/hr (k = 195)

The straight pipe inlet is approx. 40 D long for flow conditioning. A diffuser is installed downstream of the nozzle (to the right in Figure 3) to ensure flow stability. Downstream of the diffuser, critical nozzles are fitted to provide constant flow rates during the LDA measurement. With optical access, it is not only possible to operate a standard LDA, but also to test new optical methods like profile sensors and whole field sensors for further improvement. Methods like single point measurements will also be investigated. Once the boundary layers in the nozzle and in the jet exiting from the nozzle are well known for the entire range of relevant Reynolds numbers, it may be possible to reduce volume flow measurements to single point measurements. Based on existing experience, a measurement uncertainty of less than 0.1 % is expected for a wide range of pressures and flow rates. [8, 9] contain detailed descriptions of the new optical flow rate standard.

As shown in Figure 1, a bank of eight critical nozzles covering a flow range from 6.5 m³/hr to 1,600 m³/hr was installed. The position of the nozzles was selected such that they can be operated in series either with the piston prover, the new optical standard or the two new meter runs. AGA-8 calculation algorithms are implemented in the data acquisition system in order to calculate the critical flow factor C^* , the thermodynamic property essential to critical

nozzle mass flow measurements. C^* is a function of temperature, pressure and gas composition. Temperature and pressure are measured at each nozzle, gas composition through an online process gas chromatograph. The function of the critical nozzles is manifold: Firstly, they simply stabilise flow, which is important for LDA measurements. Secondly, the critical nozzles represent secondary standards of pigsar™. They make it possible to compare the two primary standards and check the reproducibility of the working and primary standards. It would also be possible to use the critical nozzles as working standards for calibrations with the new meter runs. Also, it is planned to use the nozzles as transfer standards for facility inter-comparison or calibration of other facilities against the world reference value.

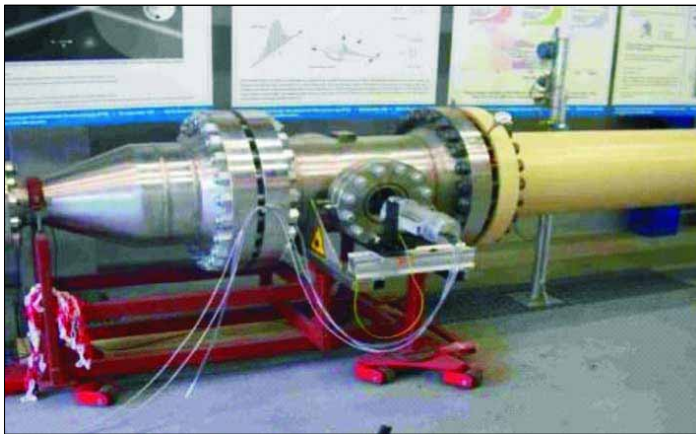

Figure 4: New optical primary standard with LDA system

3.0 LINTORF TEST FACILITY

The Lintorf high-pressure test facility is primarily used for R&D projects. The test rig is also made available for external services. The test rig, shown in Figure 5, is installed in the bypass line of the Lintorf M&R station. The technical data of the test rig are summarised in Table 2. The volume flows to be realised are dependent on the operating pressure set and are within a range of 100 m³/hr to 8,000 m³/hr (maximum flow at standard conditions: approx. 100,000 m³/hr). The maximum volume flow is dependent on the offtake situation so that the high values mentioned above can only be achieved in cold weather. As is obvious from the schematic representation in Figure 5, pressure is controlled on the inlet side while the desired volume flow is set on the outlet side by a flow control valve. The working stand (test rig standard) consists of four DN 200 orifice meter runs connected in parallel and manufactured in accordance with ISO 5167. Meter run No. 4 is equipped with a turbine gas meter and an ultrasonic gas meter. The meters and orifice meter runs are derived from pigsar™. The working standards supply the reference values with which the readouts of the meters to be tested are compared. A turbine gas meter installed permanently upstream of

the orifice plates and an ultrasonic gas meter installed downstream of the test meter run serve to check long-term stability.

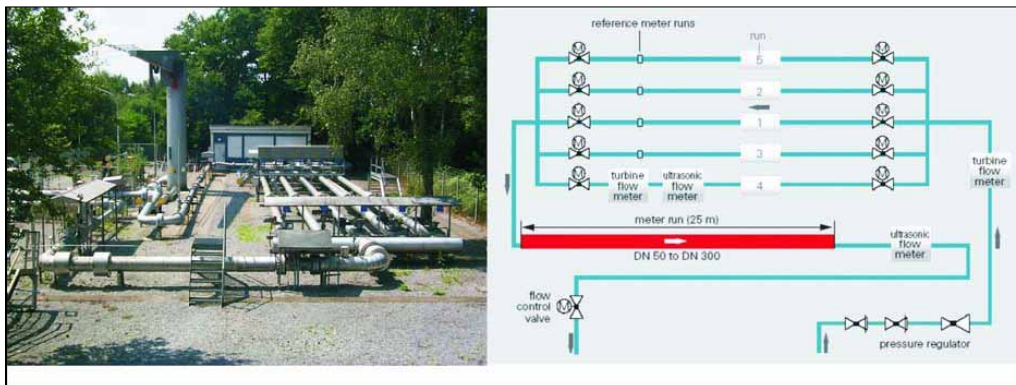

Figure 5: Lintorf high-pressure test rig

The measurement tests are made in the 25 m meter run (see Figure 5). The meter run is suitable for testing meters, controllers and valves from DN 80 to DN 300. The length of the meter run allows to realise ideal flow conditions, i.e. distinct turbulent flow, which is, for example, of great importance to the investigation of fundamental issues.

Table 2: Technical data of Lintorf high-pressure test rig

Flow range	100 m ³ (n)/hr to 100,000 m ³ (n)/hr (40,000 m ³ (n)/hr in summer)
Pressure range	16 bar to 45 bar
Test gas	low calorific naturel gas
Sizes	DN 80 to DN 300
Length of meter run	25 m
Working standars	orifice plates (calibrated individually), turbine and ultrasonic flow meters
Total uncertainty of measurement	max. 0.22 % to 0,40 %
Repeatability and reproducibility	0,1 %

Measured data acquisition is automatic and highly accurate (16-bit A/D conversion) thanks to the station computer. All data (including the calibration factors of all measurement instruments) are stored in a relational database so that each test can be traced back without loss of information even after several years.

In contrast to pigsar™, the Lintorf high-pressure test facility was designed to selectively examine specific influences and effects on gas meters and controllers.. However, the measurement technology used for the test rig is so reliable that the measurement uncertainty is less than 0.26 %for medium and high flow ranges. This is on the order of the measurement uncertainty of certified test rigs. With less than 0.1 %, repeatability is very good and this is important for analysing various factors influencing meter behaviour. The good stability of the test rig is checked, among other things, by regular comparison with pigsar™ using so-called transfer meters.

The Lintorf test rig focuses on the following:

- Internal E.ON Ruhrgas type approvals of new measurement instruments,
- R&D activities to investigate special influencing factors, solve operational problems and optimise measurement instruments and other components,
- Services for third parties,
- Examination of measurement technologies.

Under near-field conditions, the test rig examines all factors which may influence meter operation as well as their effects on measurement accuracy. Relevant factors are, for example, flow perturbations such as swirl, disturbed velocity profiles and pressure and speed pulsations. The measured data serve to

- quantify various factors influencing meter readout,
- optimise measurement instruments, and
- solve operational problems.

Detailed descriptions of the Lintorf high-pressure test rig are, for example, contained in [10,11].

4.0 GAS QUALITY CENTRE

The Gas Quality Centre of E.ON Ruhrgas makes a major contribution to ensuring accurate gas property measurement in Germany. Superior calorific value is usually measured with PGCs or, in some cases, with combustion calorimeters and also with sensor measurement systems. The measurement instruments used in fiscal metering, for example PGCs, must always first be calibrated with officially certified calibration gases and then be verified. As a state-approved test centre, the Gas Quality Centre certifies approx. 400 calibration gases and

verifies more than 100 gas property measurement instruments annually. An application for having the Gas Quality Centre accredited as a test and calibration laboratory pursuant to ISO

17025 has recently been filed. Once accredited, the certificates issued by the Gas Quality Centre will be accepted on an international level.

The calibration gases certified by the Gas Quality Centre are working standards derived from highly precise reference standards. In Germany, the reference standards (second-order calibration gases) are provided by the Federal Institute for Materials Research and Testing (BAM) in Berlin or the

Federal Institute of Physics and Metrology (PTB) in Braunschweig. In the case of calibration gases for PGCs, the working standards are determined by a chromatographic comparative PGC measurement against a reference standard. To confirm the measurement result, a comparative analysis with a laboratory GC and another check with a direct measurement method are performed additionally. For this purpose, either the standard density of the calibration gas can be measured with a gas density balance or its superior calorific value with a calorimeter. The gas will not be certified officially as a working standard until the check measurement has confirmed the results obtained with the PGC within the admissible deviations specified.

Against this background a precision densimeter has been developed by the Thermodynamics Department of Ruhr University Bochum, Germany, to accurately measure the densities of natural gases and multi-component gas mixtures at standard conditions ($t_s = 0$ °C, $p_s = 1.01325$ bar). The densimeter was developed in cooperation with E.ON Ruhrgas and delivered to the E.ON Ruhrgas test centre in Dorsten, Germany, in December 2003. Also, a reference calorimeter is being developed under a cooperation project of GERG (Groupe Européen de Recherches Gazières) and set up by PTB (see below). The reference calorimeter will be operated by the Gas Quality Centre and an accreditation according to ISO1705 is envisaged.

4.1 Precision Densimeter

Figure 6 is a photo of the reference densimeter. The density measurement principle applied is the "two-sinker density measurement method". The method was developed by the Thermodynamics Department of Ruhr University Bochum, Germany, in the early 80s. Detailed descriptions are contained in [12]. The two-sinker density measurement method is based on the Archimedes buoyancy principle which is applied in a new manner as a differential method. Instead of the usual single sinker, two sinkers are used which are specially matched to each other (see Figure 7). The two sinkers have identical masses, virtually identical surface areas and identical surface materials; however, their volumes differ strongly. To measure the density of a gas in the measuring cell, the two sinkers are alternately carried by and again removed from a sinker support connected to an electronic balance, so that the "apparent" difference in masses $m_{D, \text{gas}}$ of the sinkers surrounded by the test gas can be measured very accurately by the balance.

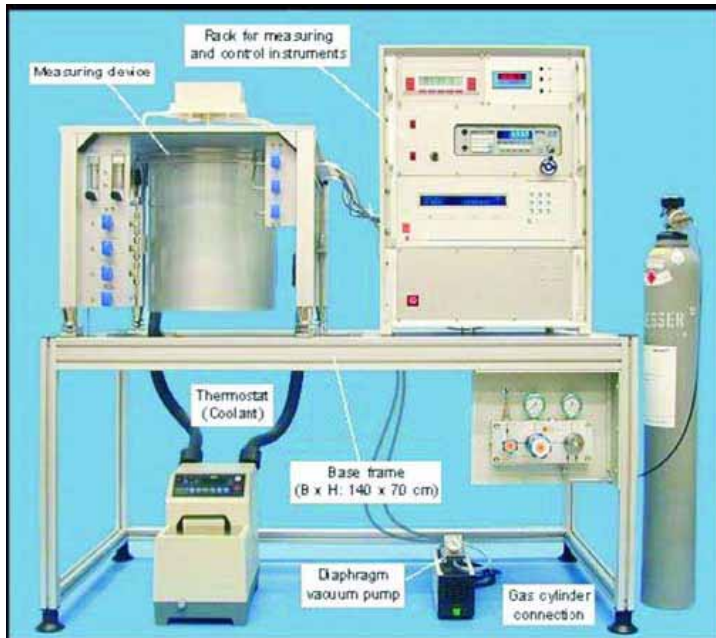

Figure 6: Reference densimeter

The density of a gas in the measuring cell at standard conditions ($t_s=0\text{ }^\circ\text{C}$, $p_s=1.01325\text{ bar}$) can now be calculated by means of a simple equation:

$$\rho_s(t_s, p_s) = \frac{m_{D,gas} - m_D}{V_D(t_s, p_s)}$$

Here, $m_{D,gas} = (m_{R,gas} - m_{C,gas})$ is the "apparent difference in the masses" of the two sinkers during weighing in a test gas, $m_D = (m_R - m_C)$ is the "true" difference in the masses of the two sinkers (indices: R = ring, C = cylinder), and $V_D(t_s, p_s) = \{V_C(t_s, p_s) - V_R(t_s, p_s)\}$ is the difference in the volumes of the two sinkers at standard conditions. The volumes of the two sinkers were calibrated by the Federal Institute of Physics and Metrology in Braunschweig at $t = 4\text{ }^\circ\text{C}$ and $t = 15\text{ }^\circ\text{C}$; from this, the difference in volumes $V_D(t_s, p_s)$ can be calculated with an uncertainty of $\pm 0.003\%$. The "true" difference in the masses of the two sinkers m_D resulting from a minor production-inherent difference in masses of around -0.56 g can be determined accurately and also simply checked, if required, by means of a reference measurement with methane.

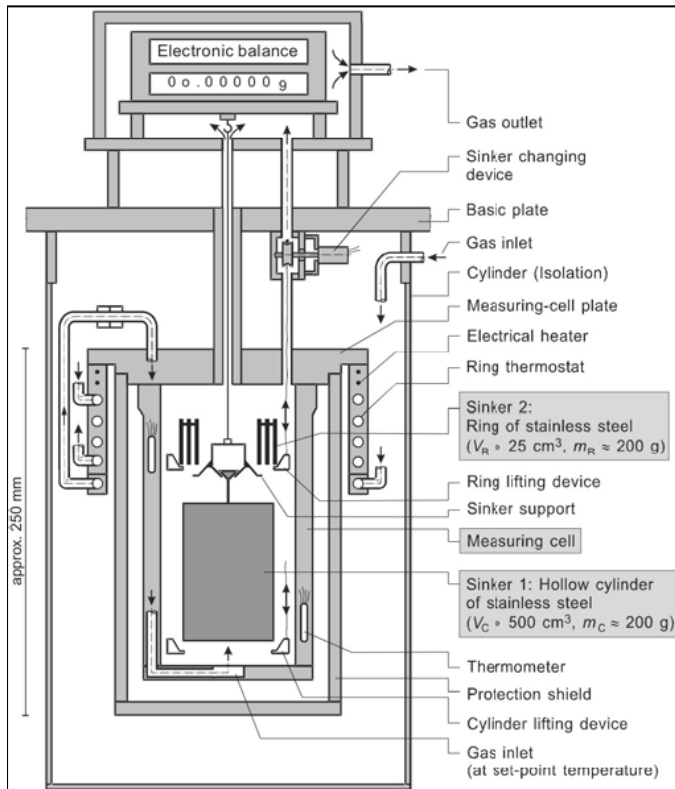

Figure 7: Design of measuring device

To increase the accuracy of the measured value $m_{D, gas}$, the two sinkers are alternated and each sinker is connected to the balance 30 times during one measurement series (30 double changes, 60 measured values, over a period of approx. 25 mins) and the statistical average is calculated. With the consistent application of the Archimedes principle as a differential method, all interfering side effects which could affect measurement accuracy are compensated for automatically with this two-sinker density measurement method. Even the effect of test gas adsorption on the sinker surfaces is compensated for, as the same mass of gas is adsorbed by approximation given identical surface areas and identical surface materials (the surfaces were polished electrolytically and subsequently gold-plated). The uncertainty associated with the measured value $m_{D, gas}$ is therefore relatively low and only amounts to ± 0.03 mg. With a test gas density between 0.7 kg/m^3 and 1.3 kg/m^3 and a resulting measured value $m_{D, gas}$ between 0.33 g and 0.62 g , this corresponds to a relative measurement uncertainty of between $\pm 0.009 \%$ and $\pm 0.005 \%$. Taking into consideration the measurement uncertainties for pressure and temperature, the total uncertainty referred to density is $\pm 0.02 \%$ (confidence level of 95 %), one of the best results obtained worldwide.

4.2 Reference Calorimeter

A GERG project⁴ was set up to develop and build a new reference calorimeter for determining the superior calorific value (SCV) of flammable gases (natural gases), based on the principle of a Rossini calorimeter. The purpose of such a reference calorimeter is to determine the SCV of pure gases and gas mixtures with an uncertainty of less than 0.05 %. The overall uncertainty budget for the SCV to be measured is mainly influenced by mass determination and temperature measurement. The reference calorimeter is described in [13].

The gas is supplied to a balance which weighs the amount of gas, m_{gas} , used for combustion. To avoid buoyancy corrections to the weighing result, this balance is placed in a vacuum chamber which may be evacuated to a pressure of less than 1 mbar. A calibration robot allows the weighing results to be traced back to the international standard of mass. The gas is fed to the burner, which is positioned in a calorimeter. The heat of combustion, H_s , causes a temperature rise, $\Delta T_{ad,comb}$, in the calorimeter. The amount of energy released in the reaction is calculated by multiplying this temperature rise by the heat capacity, $C_{cal,comb}$, of the calorimeter. K is the energy correction value.

$$\frac{m_{gas} \cdot H_s - K}{E_{elec}} = \frac{C_{cal,comb} \cdot \Delta T_{ad,comb}}{C_{cal,elec} \cdot \Delta T_{ad,elec}}$$

The heat capacity of the calorimeter is determined by electric calibration in which the electric energy, E_{elec} , leads to the same temperature increase, $\Delta T_{ad,elec}$, as in the combustion experiment. Assuming that the heat capacity does not change, the calorific value measured for the gas combusted is traced back to SI units. The assumptions used for measuring the adiabatic temperature rise for an isoperibolic system during combustion or calibration of the calorimeter are discussed in [13]. The uncertainty of the temperature rise in these two experiments makes a major contribution to the overall uncertainty of the calorimeter. Other corrections to compensate for imperfect processes have only minor effects on the overall uncertainty. These include side reactions coupled with the combustion of gases, which produce residual hydrocarbons, carbon monoxide and nitrogen oxides, and fractions of water leaving as vapour or condensing as liquid in the calorimeter. Water leaving the calorimeter as vapour results in an energy loss, water condensing inside the calorimeter changes its heat capacity.

The combustion of the sample gas takes place inside the burner immersed in the calorimeter as can be seen in Figure 8. This calorimeter vessel is surrounded by a water jacket. To minimise heat transfer due to radiation between calorimeter and water jacket, the surfaces are electrolytically polished. The calorimeter vessel, which is surrounded by a waterproof jacket, is completely immersed in a thermostatted bath. A 10 mm wide air gap between calorimeter vessel and isothermal jacket serves as thermal isolation and may reduce heat transfer due to convection. The sample gas, oxygen and argon are supplied to the burner. Argon does not participate in the reaction, but it serves to stabilise the flame and improve the combustion properties of the fuel gas [14]. In this way the flame is lifted and deposits at the burner tip are avoided [15]. A 50 Ohm heater was designed as a winding wire around

the calorimeter burner. This arrangement for calibration in the immediate vicinity of the burner approximates the arrangement of the energy source during the combustion experiment and hereby minimizes the effect of slight differences in the two heat sources on the temperature rise and field in the calorimeter.

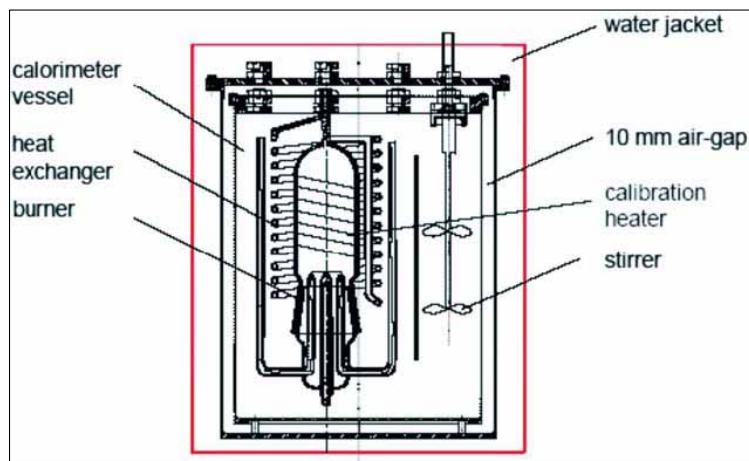

Figure 8: Schematic assembly of the gas calorimeter

The gas reference calorimeter has been set-up at PTB and work is going on to improve the repeatability of the measurement in order to finally reach an uncertainty of less than 0.05 % on a 95 % confidence level basis.

5.0 OUTLOOK

A large number of interesting developments are under way in the field of gas measurement technology, their main objective being the accurate measurement and reliability of measurement instruments. The accuracy of the instruments and materials used for calibration is of very great importance in this context. E.ON Ruhrgas has high-precision test rigs and calibration facilities available which are used for the calibration and verification of volume measurement instruments and calibration gases under the supervision of PTB. In the field of volume measurement, the laser-Doppler Anemometer developed by PTB and set up in cooperation with E.ON Ruhrgas is expected to further improve uncertainty from the current 0.16 % to possibly 0.1 %. Under a GERG project, the PTB is presently developing and setting up a reference calorimeter to be operated by the Gas Quality Centre, which is to determine the superior calorific value of natural gases with an uncertainty with less than 0.05 %. Once available, the calorimeter will be another highly accurate measurement instrument, in addition to the high-precision densimeter, for determining superior calorific value and monitoring gas properties. The prediction of thermodynamic gas behaviour is not only of great importance to gas billing but also to many technical applications, for example the calculation of flow behaviour or the design of gas transportation facilities. Therefore, E.ON

Ruhrgas has developed software for the calculation of all physical properties and processes relevant to the gas industry. The program will shortly be available as the new GasCalc 2.0 program version with a user-friendly operator interface.

6.0 REFERENCES

1. Dopheide, D., et al. (2006). CM.FF-K5: a comparison of flow rates for natural gas at high pressure. *Metrologia* 43 07001, doi:10.1088/0026-1394/43/1A/07001, <http://www.iop.org/EJ/abstract/0026-1394/43/1A/07001>.
2. Dopheide, D., et al. (2006). The international world reference value for high pressure natural gas flow as approved by CIPM key comparisons. *World Gas Conference 2006*. (submitted)
3. Vieth, D., Uhrig, M., Vulovic, F., Delenne, B. and Fabre, J.-L. (2004). New Developments in Ultrasonic Metering. *IGRC 2004 in Vancouver*.
4. pigsar™ at www.pigsar.de.
5. Mickan, M., Kramer, R., Hotze, H. -J. and Dopheide, D. (2002). PIGSAR - The Extended Test Facility and New German National Primary Standard for High Pressure Natural Gas, *Conference Proceedings, 5th International Symposium on Fluid Flow Measurement (ISFFM), Arlington, USA, 7-10 April 2002, Session 17: 1-20*.
6. Dopheide, D., Mickan, B., Kramer, R., van der Beek, M., Bloom, J. and Vallet, J.-P. (2004). The harmonized European gas cubic meter for natural gas as realized by PTB, NMi-VSL and BNM and its benefit for users and metrology. *Proceedings of the 12th International Conference on Flow Measurements (FLOMEKO'04), Guilin (Guangxi Zhuang), China, 13-18*.
7. Bremser, W., Hässelbarth, W., Kurschat, T., Hotze, H.-J. and Wendt, G. (2000). Traceability chain analysis and uncertainty budget calculation for the German national flow rate measurement standard pigsar™. *International Conference on Metrology 2000, Jerusalem, Israel*.
8. Müller, H., Strunck, V., Mickan, B., Kramer, R., Dopheide, D. and Hotze, H.-J. (2005). Das nationale Normal pigsar auf dem Weg zum europäischen Erdgaskubikmeter. *gwf-Gas/Erdgas* 146, No. 1: 33-40.
9. Müller, H., Strunck, V., Kramer, R., Mickan, B., Dopheide, D. and Hotze, H.-J. (2004). Germany's new Optical National Standard for Natural Gas of high pressure at pigsar™. *Proceedings of the 12th International Conference on Flow Measurements (FLOMEKO'04), Guilin (Guangxi Zhuang), China, 80-88*.
10. de Boer, G. and Kurth, M. (2000). Investigations regarding installation effects for small ultrasonic gas flow metering packages. *18th International North Sea Flow Measurement Workshop*.
11. Vieth, D., de Boer, G., Huijismans, F. and Buijen v. Weelden, A. (2001). Test results of a new design ultrasonic gas flow meter. *19th International North Sea Flow Measurement Workshop (2001)*.
12. Glos, S., Kleinrahm, R., Wagner, W., Schley, P., Jaeschke, M. and Uhrig, M., (2004). Präzisions-Dichtemessgerät zur genauen Messung der Normdichte von Erdgas. *gwf-Gas/Erdgas* 145, No. 7-8: 394-400.
13. Jaeschke, M., Forster, R., Schmücker, A., Pramann, A., Ulbig, P., Haloua, F., Hay, B., Le Sant, V., Loubat, S., Laguerre, D., Benito, A., Cremonesi, P. L. (2004). Development and set-up of a new reference calorimeter. *IGRC 2004 in Vancouver*.

14. Dale, A., Lythall, C., Aucott, J. and Sayer, C. (2002). *Thermochim. Acta* 382: 47-54.
15. Cowan, P. and Humphreys, A. E. (1986). The British Gas Reference Calorimeter. In: *Proceedings of the Congress of Gas Quality- Specifications and Chemical Properties of Natural Gas*, edited by G. J. van Rossum, Groningen, Elsevier Science Publishers B.V., Netherlands, 169-179.

7.0 LIST OF TABLES

Table 1: Technical data of pignar™

Table 2: Technical data of Lintorf high-pressure test rig

8.0 LIST OF FIGURES

Figure 1: Schematic presentation of pignar™

Figure 2: pignar™: Working standards and meter test sections

Figure 3: LDA nozzle module of the new optical primary standard with three exchangeable LDA nozzles A: 120 to 1,600 m³/hr (k = 18); B: 25 to 500 m³/hr (k = 49); C: 6 to 120 m³/hr (k = 195)

Figure 4: New optical primary standard with LDA system

Figure 5: Lintorf high-pressure test rig

Figure 6: Reference densimeter

Figure 7: Design of measuring device Figure 8: Schematic assembly of the gas calorimeter